

INSTRUCTION MANUAL

SIEG SUPER X3

Mill Drill - Geared & Tilting Head (240V)
(X) 400mm (Y) 150mm (Z) 350mm



M155

IMPORTANT SAFETY INSTRUCTION

READ ALL INSTRUCTIONS AND WARNINGS BEFORE USING THIS TOOL

Operator

COMMON SENSE AND CAUTION ARE FACTORS WHICH CANNOT BE BUILT INTO ANY PRODUCT. THESE FACTORS MUST BE SUPPLIED BY THE OPERATOR. PLEASE REMEMBER:

1. When using electric tools, machines or equipment, basic safety precautions should always be followed to reduce the risk of fire, electric shock, and personal injury.
2. Keep work area clean. Cluttered areas invite injuries.
3. Consider work area conditions. Do not use machines or power tools in damp, wet, or poorly lit locations. Do not expose equipment to rain, keep work area well lit. Do not use tools in the presence of flam-mable gases or liquids.
4. Keep children away, all children should be kept away from the work area.
5. Guard against electric shock. Prevent body contact with grounded surfaces such as pipes, radiators, ranges, and refrigerator enclosures.
6. Stay alert. Never operate if you are tired.
7. Do not operate the product if under the influence of alcohol or drugs. Read warning labels on prescriptions to determine if your judgment or reflexes might be impaired.
8. Do not wear loose clothing or jewelry as they can be caught in moving parts.
9. Wear restrictive hair covering to contain long hair.
10. Use eye and ear protection. Always wear.
11. Keep proper footing and balance at all times.
12. Do not reach over or across running machines.

Before operations

1. Be sure the switch is OFF when not in use and before plugging in.
2. Do not attempt to use inappropriate attachments in an attempt to exceed the tool's capacity. Approved accessories are available from the dealer or machine maker.
3. Check for damaged parts, before using any tool, any part that appears damaged should be carefully checked to determine that it will operate properly and perform its intended function.
4. Check for alignment and binding of all moving parts, broken parts or mounting fixtures and any other condition that may affect proper operation. Any part that is damaged should be prop early repaired or replaced by a qualified technician.
5. Do not use the tool if any switch does not turn off and properly

Operation

1. Never force the tool or attachment to do the work of a larger industrial tool. It is designed to do the job better and more safely at the rate for which it was intended.
2. Do not carry the tool by its power cord.
3. Always unplug the cord by the plug. Never yank the cord out of the wall.
4. Always turn off the machine before unplugging.

**IF THERE IS ANY QUESTION ABOUT A CONDITION BEING SAFE OR UNSAFE,
DO NOT OPERATE THE TOOL!**

Grounding Instructions

This machine has a three-prong plug, the third prong is the ground. Plug this cord only into a three-prong receptacle. Do not attempt to defeat the protection the ground wire provides by cutting off the round prong. Cutting off the ground will result in a safety hazard and void the warranty.

DO NOT MODIFY THE PLUG IN ANY WAY. IF YOU HAVE ANY DOUBT, CALL A QUALIFIED ELECTRICIAN.

Specification:

Max. drilling capacity:	25 mm
Max. tapping capacity:	12 mm
End mill capacity	25 mm
Face mill capacity	50 mm
Spindle stroke	80 mm
Throat	230 mm
Max. distance spindle to table	350 mm
Spindle taper	MT#3 or R8
Spindle speed	100-1750 rpm \pm 10%
Table effective size	550*160 mm
T-slot size	12 mm
Table cross travel	160 mm
Table longitudinal travel	300 mm
Motor output power	1000 W
Overall dimension(L*W*H)	685*560*830 mm
Weight (Net/Gross)	165 / 198 Kg
Packing size (L*W*H)	840*820*1040 mm

Unpacking & Preparing for Use

Before unpacking you must check the package carefully, to find whether it is damaged and any may have effect on the machine, please connect with the distributor in advance.

Unpacking carefully, check the species of standard accessories and the quantity to find whether it is as same as the packing list in the package.

FEATURE

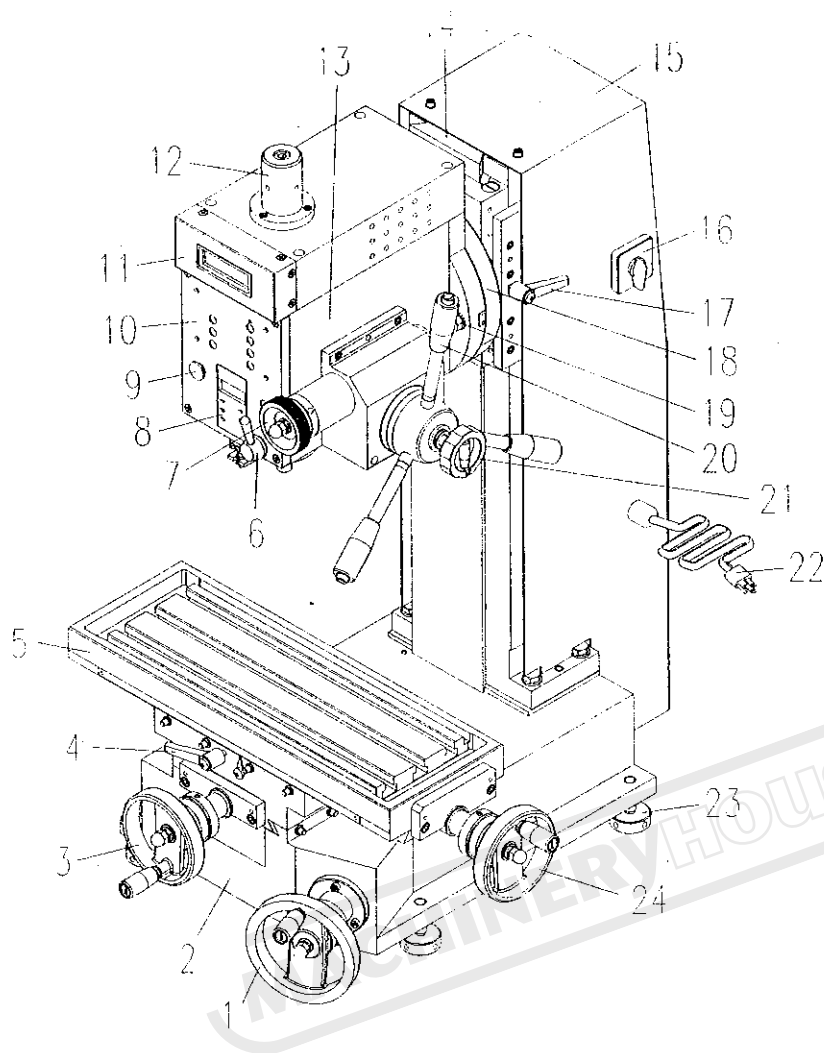

1	Lifting handwheel	13	Spindle box
2	Base	14	Fuselage
3	Cross feed handwheel	15	Cover for fuselage
4	Lock handle	16	Power switch
5	Worktable	17	Lock handle
6	Spindle lock handle	18	Rotate connect plate
7	Fine feeding handwheel	19	Lock bolt
8	Depth display	20	With tapping handle
9	Emergency stop switch	21	Fine feeding lock handle
10	Touch Switch panel	22	Power plug
11	Rotate speed display	23	Adjust bolt
12	Protective cover	24	Longitudinal handwheel

Installation

CAUTION!

DO NOT ATTEMPT TO USE THE MACHINE UNTIL INSTALLTION IS CAMPLETED, AND ALL PRELIMINARY CHECKS HAVE BEEN MADE IN ACCORDANCE WITH THIS MANUAL.

MOUNTING THE MACHINE

The machine should be mounted on a strong, heavy workbench, of sufficient height so that you do not need to bend your back to perform normal operations.

Ensure the location is adequately lit and that you will not be working in your own shadow.

We strongly recommend that the machine bolted firmly to strong workbench using the tapped holes used to secure the feet to the machine. This is to provide added stability and consequently, additional safety.

To do this, first drill four M12 clearance holes in a worktop, at the dimensions shown in the diagram opposite, and with appropriate length M12 bolts, or screws, with flat washers. (not supply).

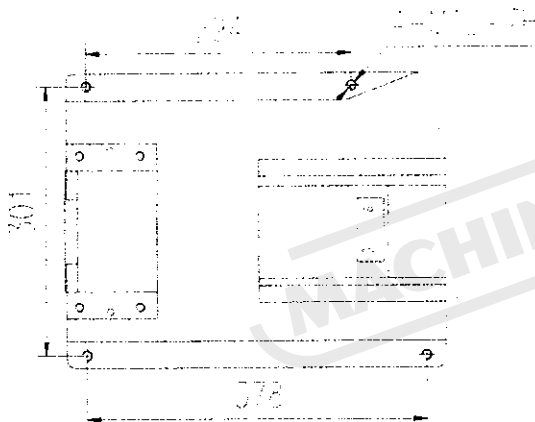

Application

This small mill machine is both for milling or drilling and tapping, widely used in different places. Fine exterior, wide range of speed and easy to use.

Designed for industrial usage milling, drilling, tapping, reaming, steps and mill plane with metal and other material.

Operation

1. Before starts to use this machine, operator should go through the instructions carefully so as to acquaint with the construction of the machines, the functions of the various controls and also the driving systems.

2. This machine uses touching button (see operation panel below), operating steps refer to the flow chart.

Spindle speed readout →

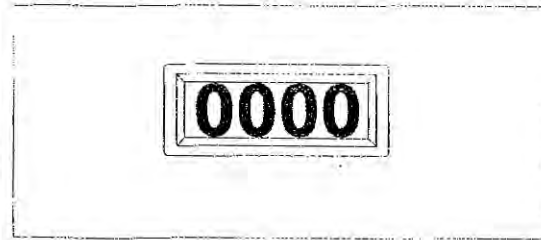

Operation panel

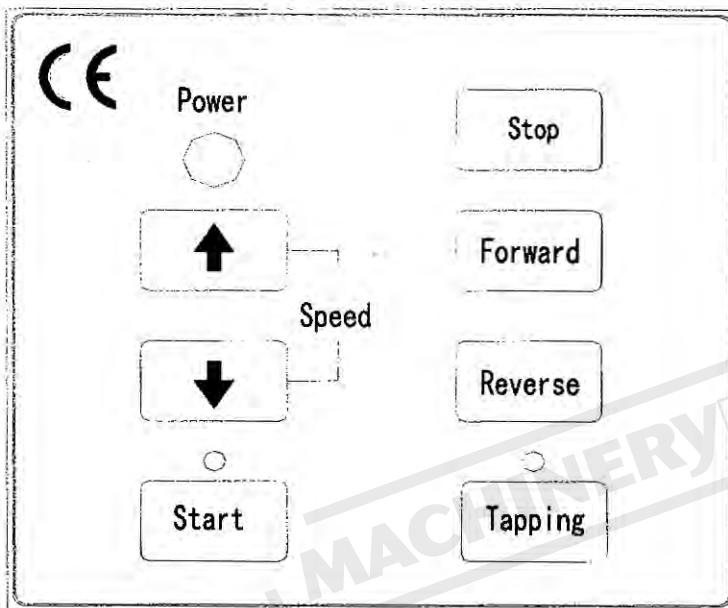

Spindle depth readout

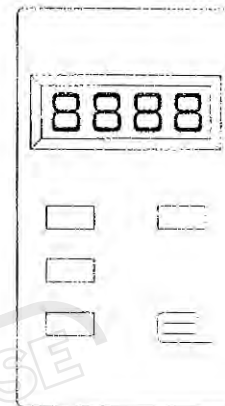

Operating steps

1. Insert the electric plug into its socket. Turn the power switch (on left) to 'I' position, the power indicator lights (green, in front of the spindle box).
2. Release the Emergency stop switch by turning the round head of the switch, the Spindle speed readout shows '0000'.
3. Press 'Start' button on the touching panel, the light above 'Start' button lights, spindle speed readout shows '0100 FORWARD'. Notice: '0100' is the lowest speed of this machine.
4. Press '↑' button, speed increase, press '↓' button, speed decrease.
5. Press 'Stop' button, spindle stop running, if press 'Start' button now, spindle runs to the speed last setting automatically.
6. Press the "Tapping" button, the light above the 'Tapping' button lights. This means now is the 'Tapping mode', 'Forward' and 'Reverse' buttons are unavailable

7. Taping: the highest speed under 'Tapping mode' is 500rpm. Press the button end of the handle the first is "forward" when press again it change to "reverse".

8. Fine feeding function: When lock the Lock small handwheel (A), then the control handle (B) can not useable. Turn the fine feeding handwheel (C) the spindle will micro remove.

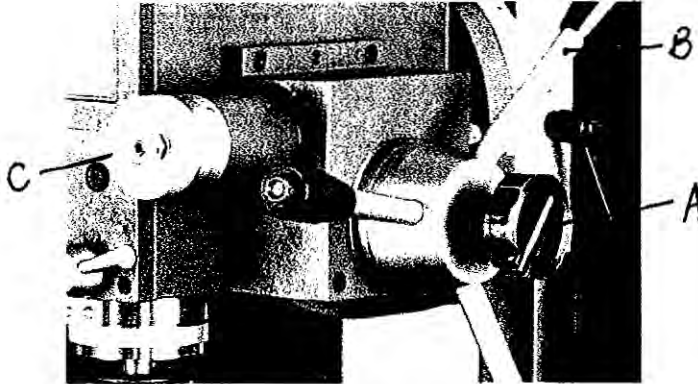
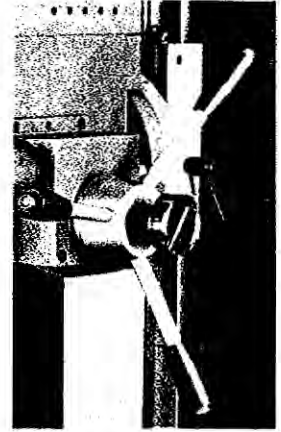

9. The Mill machine have a big feature: It can do angle milling and horizontal milling. You need purpose a optional accessories the worktable. See below pictures.

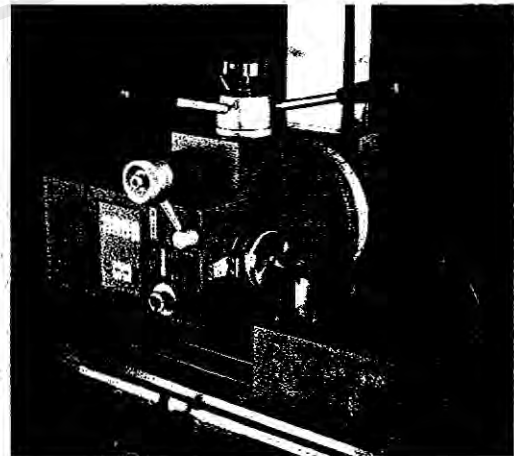

Notice:

The highest spindle speed in REVERSE direction is a half of when in FORWARD direction.

After using should turn the power switch to position '0' and pull out the plug from socket.

Flow chart

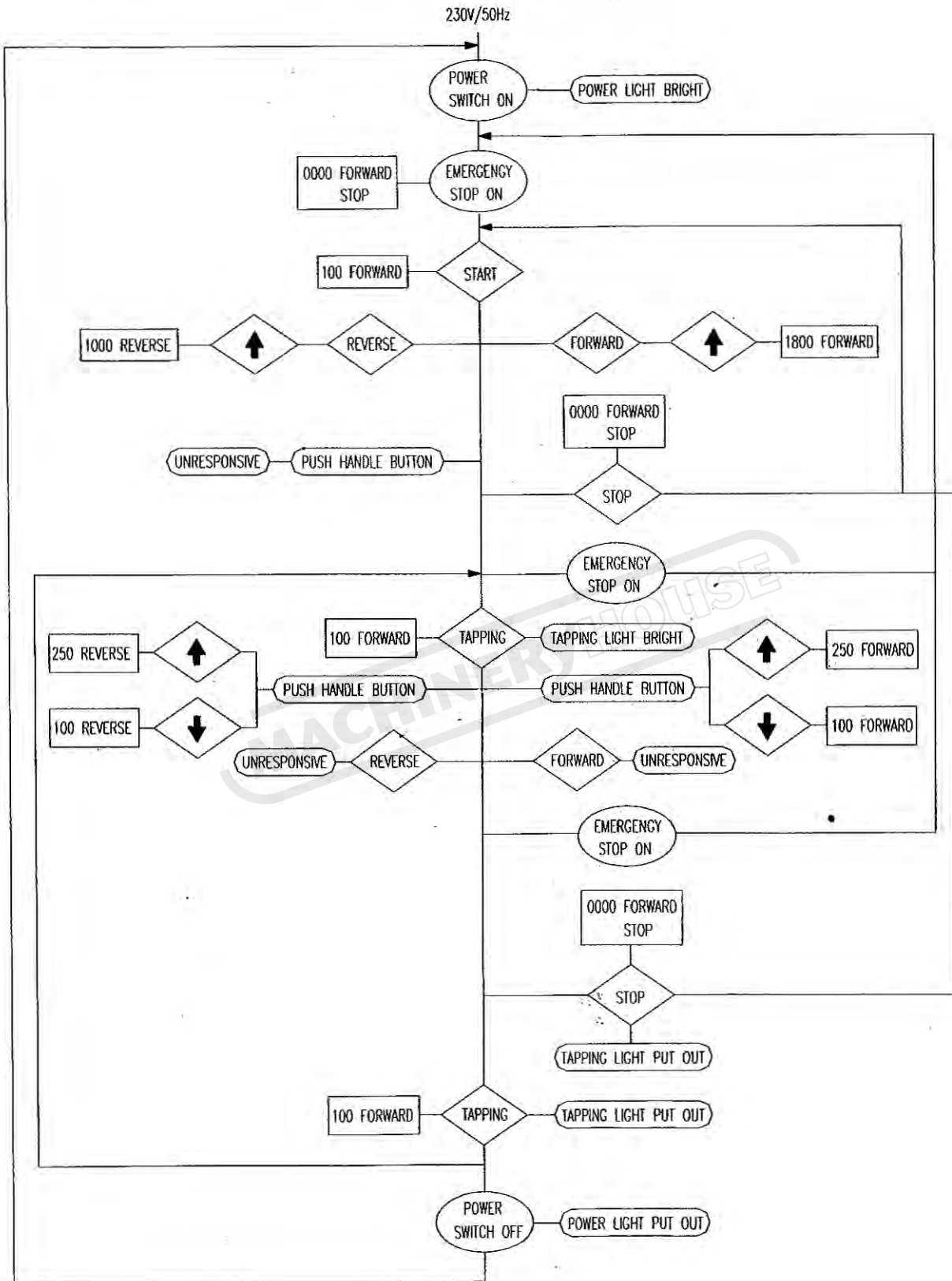

Parts drawing (I)

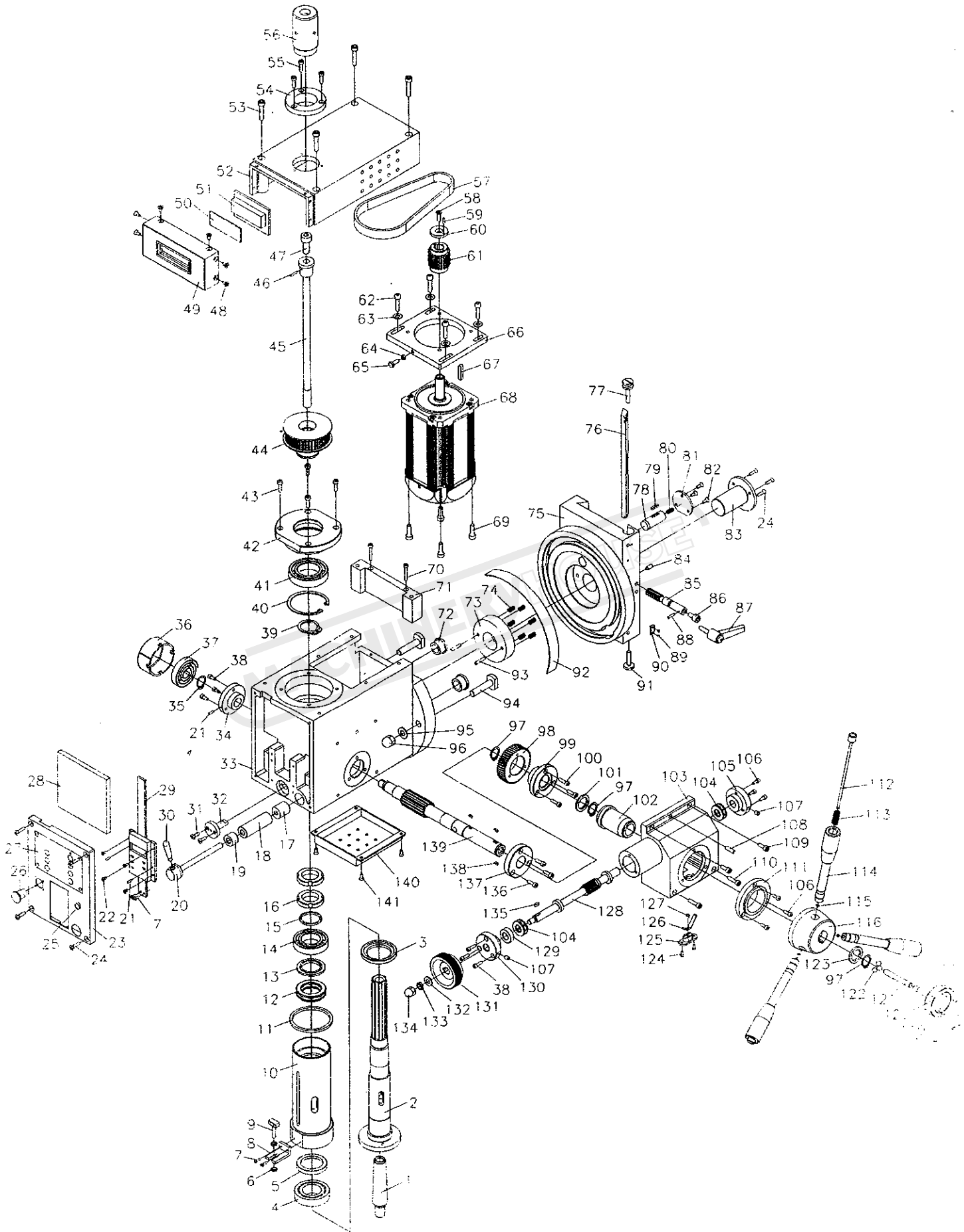

Parts drawing (II)

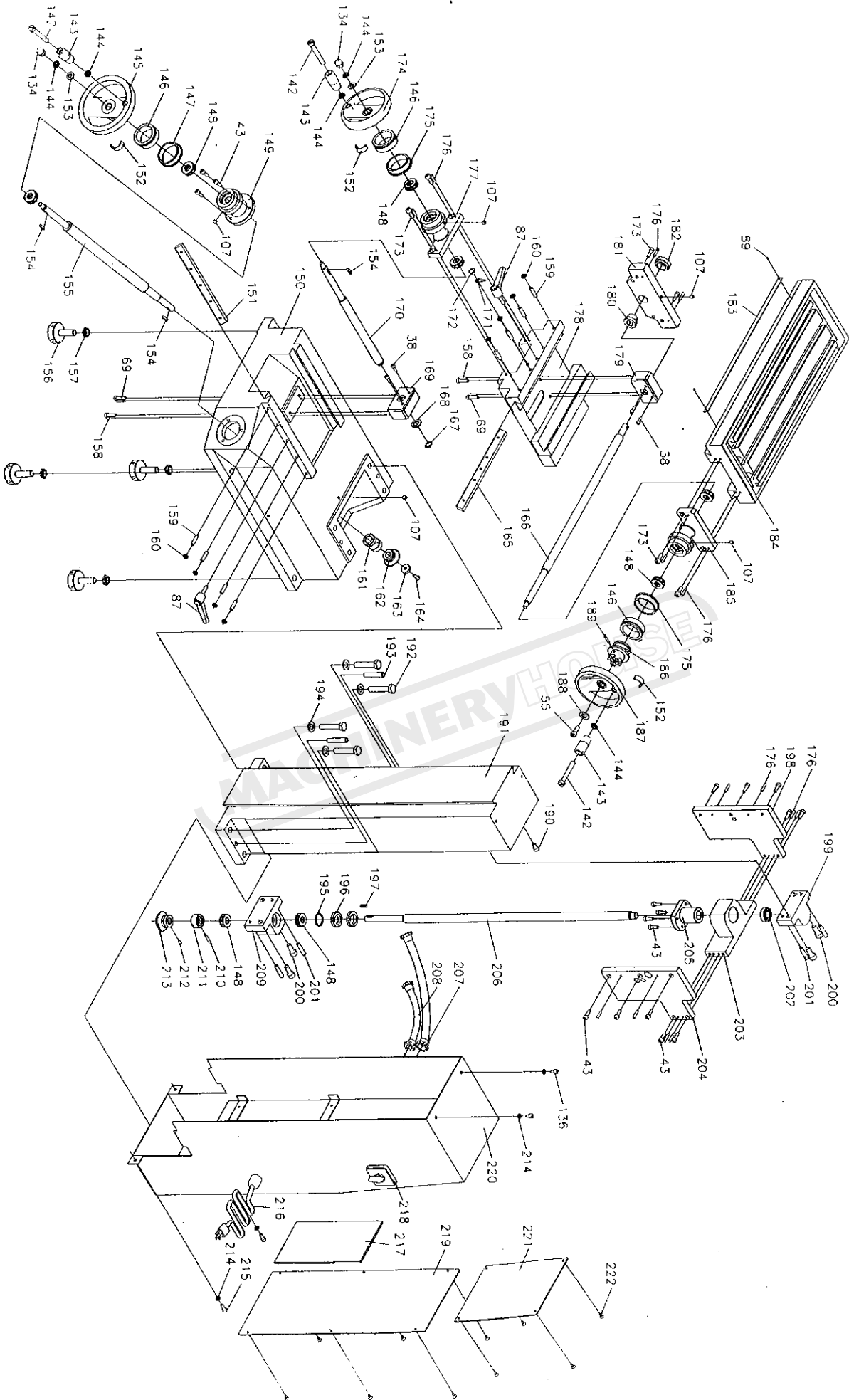

Parts list

No.	Description	Q'ty	No.	Description	Q'ty
1	Taper shank	1	40	Check ring 65	1
2	Spindle	1	41	Bearing 80107	1
3	Under oil seal I	1	42	bearing seat	1
4	Taper bearing 32907	1	43	Screw M5*16	21
5	Under oil swal II	1	44	Synchronization pulley	1
6	Nut M5	2	45	lock bolt	1
7	Screw M3*8	4	46	Taper pin 3*18	1
8	Display fixed bracket	1	47	Screw M10*16	1
9	Square screw	1	48	Screw M4*6	6
10	Spindle sleeve	1	49	Cover	1
11	Sleeve limit pad	1	50	Block piece	1
12	Bearing 8106	1	51	Rotate speed display	1
13	Upper washer II	1	52	Spindle box cover	1
14	Bearing 80106	1	53	Screw M6*40	4
15	Upper washer I	1	54	Dustproof cover I for spindle	1
16	Small round nut M27*1.5	2	55	Screw M4*10	4
17	Spindle sleeve brake sleeve II	1	56	Dustproof cover II for spindle	1
18	Spindle sleeve brake sleeve I	1	57	Timing belt	1
19	Deep washer	1	58	Screw M6*16	1
20	Lock bolt	1	59	Pin 3*10	1
21	Spring round pin 3*8	3	60	Washer	1
22	Screw M3*8	4	61	Motor timing pulley	1
23	Switch panel	1	62	Screw M6*20	4
24	Screw M4*16	7	63	Washer 6	4
25	Indicator light	1	64	Nut M5	1
26	Emergency stop switch	1	65	Bolt M5*25	1
27	Touch panel	1	66	Motor support plate	1
28	PC Board	1	67	Key 5*25	1
29	Electron display	1	68	brushless motor	1
30	Small handle	1	69	Screw M5*20	8
31	Screw M3*10	2	70	Screw M4*35	2
32	Spindle sleeve orientation shaft	1	71	Spindle box paneling	1
33	Spindle box	1	72	Orientation steel sleeve	2
34	Left support flange	1	73	Rub circle	1
35	Check ring 16	1	74	Compress spring 1*6*20	6
36	Check spring cover	1	75	Vertical slide	1
37	Clockwork spring	1	76	Tilted wedge	1
38	Screw M4*12	10	77	Adjusting screw	1
39	Check ring 35	1	78	orientation small gear shaft	1

No.	Description	Q'ty	No.	Description	Q'ty
79	key 4*12	1	119	Assistant small handle	1
80	Compress spring 0.7*4.7*25	1	120	Worm wheel lock handle	1
81	Cover board	1	121	lock small shaft	1
82	Screw M4*10	3	122	Steel ball 8	3
83	Center orientation shaft	1	123	Adjust mat	1
84	Screw M6*8	1	124	Screw M3*6	2
85	Small gear shaft	1	125	Touch fastness fight	1
86	Inlay shaft	1	126	Guide electricity bar	1
87	Small handle assembly	3	127	Screw M3*6	1
88	Taper pin 3*10	1	128	Worm	1
89	Scutcheon rivet	4	129	Worm adjust mat	1
90	indication brand	1	130	Worm left support flange	1
91	Adjust screw	1	131	Worm handwheel	1
92	Staff guage	1	132	Washer 8	1
93	Pin 5*20	2	133	Nut M8	1
94	T screw	2	134	Cup nut M8	3
95	Washer 10	2	135	Key 4*10	1
96	T screw	2	136	Screw M5*12	5
97	Check ring 20	3	137	Right support flange I	1
98	Tilted gear	1	138	Key 6*8	3
99	Fastness sleeve	1	139	Gear shaft	1
100	Screw M4*16	3	140	Spindle box below cover	1
101	Washer I	1	141	Screw M4*10	4
102	Guide electricity assembly	1	142	Screw M8*55	3
103	Worm support box	1	143	Handle sleeve	3
104	Bearing 8101	2	144	Nut M8	5
105	Worm right support flange	1	145	Handle wheel	1
106	Screw M4*10	6	146	Dial	3
107	Cup oil 6	7	147	Inlay circle	1
108	Screw 6*20	1	148	Bearing 51101	8
109	Screw M5*16	2	149	Support flange	1
110	Screw M5*20	2	150	Base	1
111	Right support flange II	1	151	Cross wedge	1
112	Joy stick	3	152	Reed	3
113	Compress 0.7*6*25	3	153	Washer 8	2
114	Handle assembly	3	154	Key 4*16	3
115	Check ring 4	3	155	Rotate shaft	1
116	Big handle seat	1	156	Adjust bolt	1
117	Small magnetism block	1	157	Nut M12	4
118	Pin 3*14	1	158	Taper pin 3*20	4

Parts list (III)

No.	Description	Q'ty	No.	Description	Q'ty
159	Screw M6*25	8	199	Upper bearing seat	1
160	Nut M6	8	200	Screw M8*20	4
161	Shaft sleeve	1	201	Taper pin 6*30	4
162	Taper gear	1	202	Bearing 80101	1
163	Washer	1	203	Support fight	1
164	Screw M5*14	1	204	Side support plate I	1
165	Portrait wedge	1	205	Verticality leadscrew nut	1
166	Portrait leadscrew	1	206	Verticality leadscrew	1
167	Check ring 12	1	207	Tube connector	4
168	Washer	1	208	Tube	2
169	Cross leadscrew nut	1	209	Below bearing seat	1
170	Cross leadscrew	1	210	Taper pin 4*26	1
171	Finger	1	211	Limit sleeve	1
172	Screw M6*6	1	212	Set screw M5*8	1
173	Screw M6*16	6	213	Taper gear II	1
174	Handwheel	1	214	Washer 5	4
175	Inlay circle	2	215	Screw M5*8	2
176	Taper pin 4*20	14	216	Power line	1
177	Bearing Seat	1	217	PC Board	1
178	Saddle	1	218	Power switch	1
179	Portrait leadscrew nut	1	219	Cover II	1
180	left bearing sleeve	1	220	Back cover	1
181	Left support	1	221	Cover II	1
182	Left support stop up	1	222	Screw M4*5	10
183	Staff guage	1			
184	Work table	1			
185	Portrait leadscrew bearing seat	1			
186	Leadscrew clutch	1			
187	Handwheel	1			
188	Washer	1			
189	Pin 4*28	1			
190	Screw M6*10	1			
191	Verticality lead rail	1			
192	Bolt M10*50	4			
193	Taper pin 6*40	2			
194	Washer 10	4			
195	Washer	1			
196	Small round nut M16*1.5	2			
197	Key 4*20	1			
198	Side support plate II	1			

Circle drawing

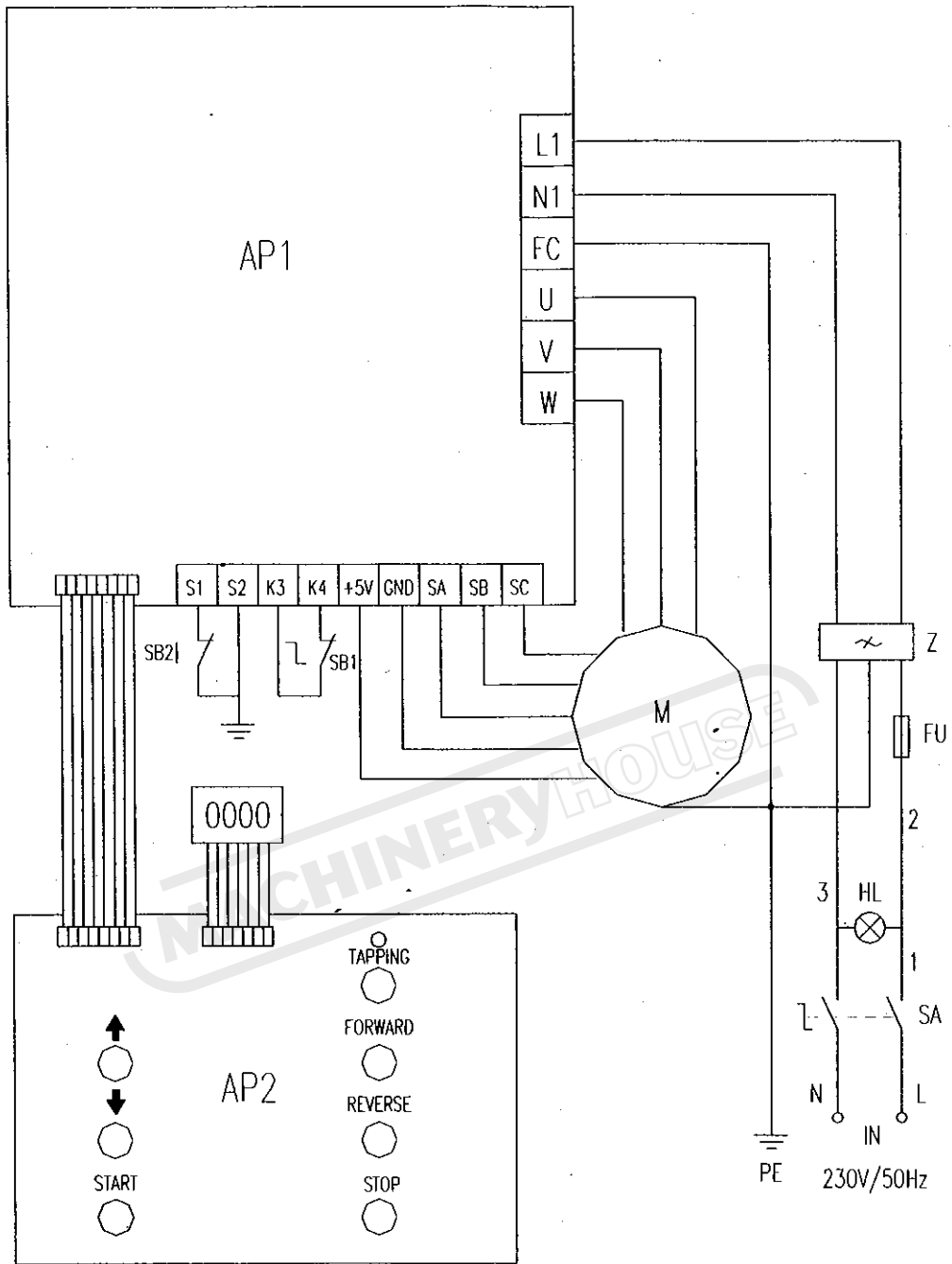

Packing List

No.	Description	Q'ty	Remarks
1	Drill chuck with taper shank and key	1	
2	L Hex. Wrench S:3,4,5,6,	4	
3	Double end wrench: 8*10; 14*17;17*19	3	
4	Oil cup	1	
5	T-nut	2	
6	Tilted wedge	1	
7	L Hex. Wrench assembly	1	
8	Lock wrench	1	
9	Fuse	1	
10	manual	1	

MACHINERYHOUSE